

J. SCHREIBER.  
Spring-Motor.

No. 199,470.

Patented Jan. 22, 1878.

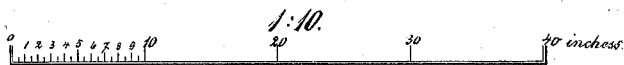
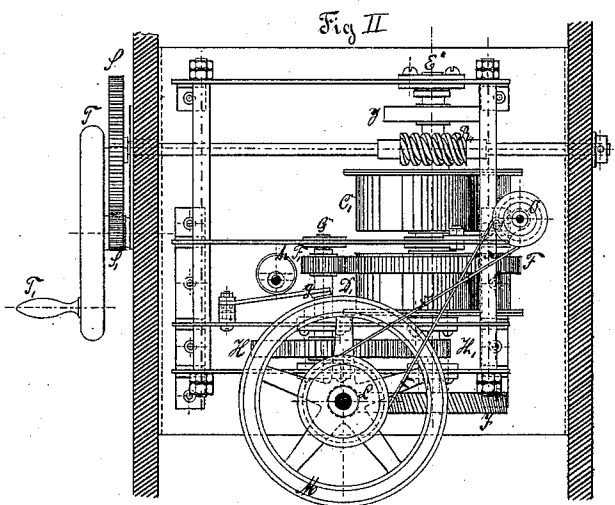
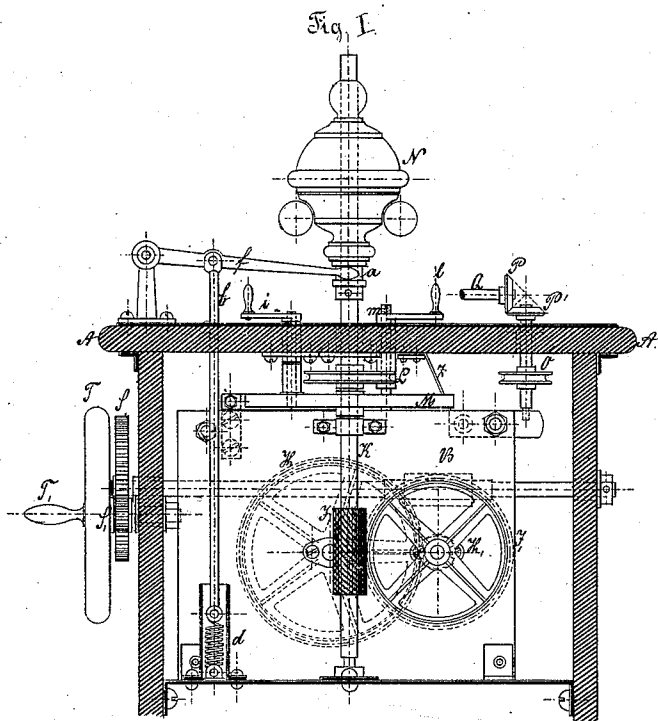

Witnesses  
*A. Scott*  
*Thos. W. Hay*

Inventor  
*Josef Schreiber*  
per *Attorney*  
Attorney

J. SCHREIBER.  
Spring-Motor.

No. 199,470.

Patented Jan. 22, 1878.

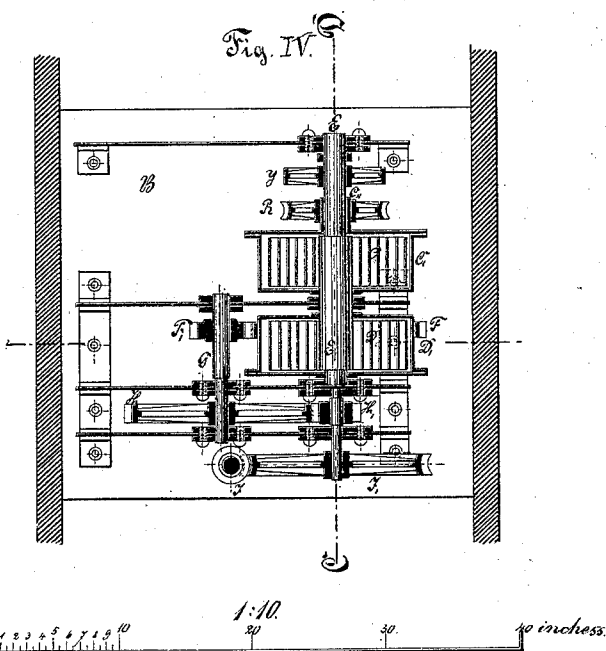
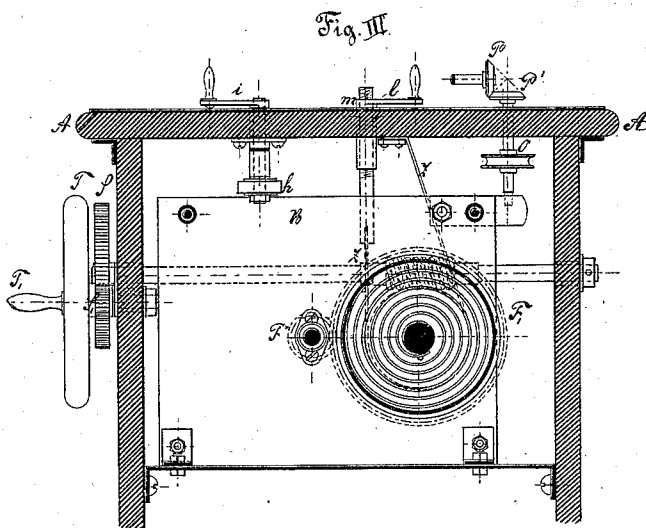

Witnesses  
*R. Scott*  
*Flora Willey*

Inventor  
*Josef Schreiber*  
per *Schreiber*  
Attorney



# UNITED STATES PATENT OFFICE.

JOSEF SCHREIBER, OF VIENNA, AUSTRIA.

## IMPROVEMENT IN SPRING-MOTORS.

Specification forming part of Letters Patent No. 199,470, dated January 22, 1878; application filed January 4, 1878.

### *To all whom it may concern:*

Be it known that I, JOSEF SCHREIBER, of the city of Vienna, Empire of Austria, have invented certain improvements in machines moved by spring-power, to be used with all kinds of sewing and other small machines, designated as the "elasticity-motor," of which the following is a specification:

The present invention relates to improvements in spring-motors for driving sewing-machines and other light machinery; and it consists in the construction and arrangement of devices which will be hereinafter fully explained, and specifically set forth in the claims.

In the accompanying drawings, forming part of this specification, Figure 1 is a front elevation, partly in section, of my improved motor. Fig. 2 is a horizontal cross-section of the same. Fig. 3 is a vertical longitudinal section. Fig. 4 is a horizontal cross-section, taken through the spring-barrels. Fig. 5 is a vertical cross-section, and Fig. 6 is a rear elevation of the motor.

The motor illustrated in the present instance is designed for operating a Wheeler & Wilson sewing-machine, and is arranged within a metallic casing or shell, B, which is located beneath the table top A of the machine.

The casing B is divided into several compartments by means of longitudinal partition-walls, so as to separate the different parts of the driving-gear from each other.

The power for driving the motor are coiled springs C D, which are fitted in shells or casings C<sup>1</sup> and D<sup>1</sup>, mounted or arranged on the shaft E, in such a manner as to turn on said shaft.

The shell C<sup>1</sup> has a sleeve or box, C<sup>2</sup>, which encircles the shaft E, and upon this sleeve is keyed a worm-wheel, R, into which meshes a screw, R'. The latter is mounted upon a horizontal shaft, which is rotated by spur-gearing S and S' and a fly-wheel, T, having a crank, T'.

The mechanism above described acts upon the casing or shell C<sup>1</sup> to wind up the spring contained within the same; and as said spring is attached to the shaft E, it will serve to turn the latter and cause the spring D to expend its force upon the casing D<sup>1</sup>. The latter has a circumferential toothed rim, F, which trans-

mits the power or force of the springs to the driving mechanism connected directly with the main shaft of the sewing-machine.

As shown in Fig. 6, the toothed rim above referred to engages with a pinion, F', on the shaft G, and this shaft bears a large spur-wheel, H, which meshes into a pinion, H', fitted on a short independent shaft. A large screw-wheel, I, on said short shaft engages with a screw-pinion, I', on the vertical shaft K, which is provided with a fly-wheel, M, and belt-pulley L, for transmitting motion by means of a crossed belt, *x*, to a short vertical shaft, O. The latter operates the main shaft Q of the sewing-machine, the two shafts being connected by bevel-gearing P P'.

The vertical shaft K bears at its upper end a regulator, N, which has a sleeve, *a*, connected with an end-fulcrumed lever, *f*. The latter is also connected with a vertical rod, *b*, the lower end of which is attached to a spiral spring, *d*.

The devices last described serve to regulate the speed of the machine in an automatic manner, the regulator N being raised by centrifugal force, so as to overcome the pressure of the spring *d*, which at other times holds the regulator in its normal position.

In order to enable the speed of the machine to be regulated by hand, and to arrest the motion entirely, I provide a brake device or mechanism, consisting of a spring-arm and friction-block, *g*, the latter bearing upon the balance-wheel M when it is pressed upon the same by means of an eccentric, *h*; and vertical shaft *i*. The latter projects through the table top, and has a handle, moving over an index-plate, so as to operate the eccentric in a simple and effective manner.

The arrangement of two coiled springs in the manner described will enable the springs to be wound up while the machine is in motion, and without retarding the speed of the same, because it will be perceived that while the outer spring is being wound up the inner spring D will alone furnish the necessary power.

The shaft E may also be provided with a pulley, Y, having an encircling brake or friction-band, Z, the ends of which are attached to a fixed support, and a screw-stem, *m*, the

latter having a handle, *t*. The object of these devices is to arrest the rotation of the shaft E when desired.

Instead of the construction heretofore described, I may use a single shell or casing, containing one or more coiled springs, preferably two, this casing being provided with apertures, end caps, or heads, and fitted loosely on its shaft. In this instance the shaft bears a large spur-wheel, for transmitting the power from the spring to the other devices.

Having thus described my invention, what I claim as new, and desire to secure by Letters Patent, is—

1. In a spring-motor, the combination of two independent coiled springs, fitted within shells or casings, upon a single shaft, with winding and power-transmitting devices, substantially as herein set forth.

2. The combination of the shaft E, spring-barrels C C' D D', spur-rim F, pinion F', shaft G, spur-wheel H, pinion H', and screw-wheels I I' with the vertical shaft O and direct driving mechanism of the machine, as and for the purpose set forth.

3. The combination of the shaft *i*, provided with a handle, eccentric *h*, and spring brake-arm *g*, with the balance-wheel and motor mechanism, as and for the purpose set forth.

In testimony whereof I have signed my name to this specification in presence of two subscribing witnesses.

JOSEF SCHREIBER.

Witnesses:

MAXIMILIAN MARCUS LOWIMDAHL,  
JOACHIM HAMERSCHLAG.